



Main

Range of product	Altivar Machine ATV340
Product or component type	Variable speed drive
Device application	Machine
Device short name	ATV340
Variant	Standard version
Product destination	Asynchronous motors Synchronous motors
Mounting mode	Cabinet mount
EMC filter	Integrated with <= 20 m motor cable maxi conforming to EN/IEC 61800-3 category C3
IP degree of protection	IP20 conforming to IEC 61800-5-1 IP20 conforming to IEC 60529
Type of cooling	Forced convection
Supply frequency	50...60 Hz +/- 5 %
Network number of phases	3 phases
[Us] rated supply voltage	380...480 V - 15...10 %
Motor power kW	7.5 kW (normal duty) 5.5 kW (heavy duty)
Motor power hp	10 hp (normal duty) 7 hp (heavy duty)
Line current	20 A at 380 V without line choke (heavy duty) 16 A at 480 V without line choke (heavy duty) 15.3 A at 380 V with external line choke (normal duty) 12.2 A at 480 V with external line choke (normal duty) 11.6 A at 380 V with external line choke (heavy duty) 9.4 A at 480 V with external line choke (heavy duty)
Prospective line Isc	22 kA
Apparent power	12.1 kVA at 480 V (normal duty) 13.3 kVA at 480 V (heavy duty)
Continuous output current	16.5 A at 4 kHz (normal duty) 12.7 A at 4 kHz (heavy duty)
Maximum transient current	19.1 A during 60 s (heavy duty)

Disclaimer: This documentation is not intended as a substitute for and is not to be used for determining suitability or reliability of these products for specific user applications

	18.2 A during 60 s (normal duty) 22.3 A during 2 s (normal duty) 22.9 A during 2 s (heavy duty)
Asynchronous motor control profile	Constant torque standard Variable torque standard Optimized torque mode
Synchronous motor control profile	Permanent magnet motor Reluctance motor
Speed drive output frequency	0.1...599 Hz
Nominal switching frequency	4 kHz
Switching frequency	7...16 kHz with derating factor 2...16 kHz adjustable
Safety function	STO (safe torque off) SIL 3

Complementary

Discrete input logic	16 preset speeds
Communication port protocol	Ethernet/IP Modbus serial Modbus TCP
Option card	Slot GP-X : digital and analog I/O extension module Slot GP-X : output relay extension module Slot GP-ENC : 5/12 V digital encoder interface module Slot GP-ENC : analog encoder interface module Slot GP-ENC : resolver encoder interface module
Output voltage	<= power supply voltage
Permissible temporary current boost	1.1 x I _n for 60 s (normal duty) 1.5 x I _n for 60 s (heavy duty) 1.35 x I _n for 2 s (normal duty) 1.8 x I _n for 2 s (heavy duty)
Motor slip compensation	Adjustable Automatic whatever the load Can be suppressed Not available in permanent magnet motor law
Acceleration and deceleration ramps	S, U or customized Linear adjustable separately from 0.01...9999 s
Braking to standstill	By DC injection
Protection type	Motor: thermal protection Drive: thermal protection Drive: overheating Drive: line supply overvoltage Drive: line supply undervoltage Drive: break on the control circuit Motor: safe torque off Drive: safe torque off Drive: short-circuit between motor phases Motor: motor phase loss Drive: overcurrent Drive: output overcurrent between motor phase and earth Drive: output overcurrent between motor phases Drive: short-circuit between motor phase and earth Drive: motor phase loss Drive: DC Bus overvoltage Drive: input supply loss Drive: exceeding limit speed
Frequency resolution	Display unit: 0.1 Hz Analog input: 0.012/50 Hz
Electrical connection	Screw terminal with clamping capacity: 4...6 mm ² , AWG 12...AWG 10 on DC bus Screw terminal with clamping capacity: 0.2...2.5 mm ² , AWG 24...AWG 12 on control Screw terminal with clamping capacity: 1.5...6 mm ² , AWG 14...AWG 10 on line side Screw terminal with clamping capacity: 1.5...6 mm ² , AWG 14...AWG 10 on motor
Connector type	Connector(S)1 x RJ45, Modbus serial on front face Connector(S)1 x RJ45, Modbus serial for HMI on front face Connector(S)2 x RJ45, Ethernet IP/Modbus TCP on front face
Physical interface	2-wire RS 485 Modbus serial
Transmission frame	RTU Modbus serial

Transmission rate	10/100 Mbit/s Ethernet IP/Modbus TCP 4800 bps, 9600 bps, 19200 bps, 38.4 Kbps Modbus serial
Exchange mode	Half duplex, full duplex, autonegotiation Ethernet IP/Modbus TCP
Data format	8 bits, configurable odd, even or no parity Modbus serial
Type of polarization	No impedance Modbus serial
Number of addresses	1...247 Modbus serial
Method of access	Slave Modbus TCP Slave Modbus RTU
Supply	External supply for digital inputs : 24 V DC (19...30 V), <= 1.25 mA, protection type: overload and short-circuit protection Internal supply for reference potentiometer (1 to 10 kOhm) : 10.5 V DC +/- 5 %, <= 10 mA, protection type: overload and short-circuit protection Internal supply for digital inputs and STO : 24 V DC (21...27 V), <= 200 mA, protection type: overload and short-circuit protection
Local signalling	4 LED, mono/dual colour for local diagnostic 4 LED, dual colour for communication module status
Width	110 mm
Height	270 mm
Depth	234 mm
Product weight	2.9 kg
Analogue input number	2
Analogue input type	AI1 software-configurable current : 0...20 mA, impedance 250 Ohm, resolution 12 bits AI1 software-configurable temperature probe or water level sensor AI1 software-configurable voltage : 0...10 V DC, impedance 31.5 kOhm, resolution 12 bits AI2 software-configurable voltage : - 10...10 V DC, impedance 20 kOhm, resolution 12 bits
Discrete input number	8
Discrete input type	PTI programmable as pulse input : 0...30 kHz, 24 V DC (<= 30 V) STOA, STOB safe torque off, 24 V DC (<= 30 V), impedance > 2.2 kOhm DI1...DI5 programmable, 24 V DC (<= 30 V), impedance 4.4 kOhm
Input compatibility	DI1...DI5 : discrete input level 1 PLC conforming to EN/IEC 61131-2 PTI : pulse input level 1 PLC conforming to IEC 65A-68 STOA, STOB : discrete input level 1 PLC conforming to EN/IEC 61131-2
Discrete input logic	DI1...DI5 positive logic (source) at State 0: < 5 V, at State 1: > 11 V DI1...DI5 negative logic (sink) at State 0: > 16 V, at State 1: < 10 V PTI positive logic (source) at State 0: < 0.6 V, at State 1: > 2.5 V STOA, STOB positive logic (source) at State 0: < 5 V, at State 1: > 11 V
Analogue output number	1
Analogue output type	Software-configurable voltage AQ1 : 0...10 V DC impedance 470 Ohm, resolution 10 bits Software-configurable current AQ1 : 0...20 mA impedance 500 Ohm, resolution 10 bits
Input/Output type	Programmable as logic input/output DQ1 : 0...1 kHz, <= 30 V DC, 100 mA Programmable as logic input/output DQ2 : 0...1 kHz, <= 30 V DC, 100 mA
Sampling duration	Discrete input DI1...DI5 : 2 ms (+/- 0.5 ms) Pulse input PTI : 5 ms (+/- 1 ms) Analog input AI1, AI2 : 1 ms (+/- 1 ms) Analog output AQ1 : 5 ms (+/- 1 ms) Discrete input/output DQ1, DQ2 : 2 ms (+/- 0.5 ms)
Accuracy	Analog input AI1, AI2 : +/- 0.6 % for a temperature variation 60 °C Analog output AQ1 : +/- 1 % for a temperature variation 60 °C
Linearity error	AI1, AI2 : +/- 0.15 % of maximum value for analog input AQ1 : +/- 0.2 % for analog output
Relay output number	2
Relay output type	Configurable relay logic R1 : fault relay NO/NC 100000 cycles at maximum switching current Configurable relay logic R2 : sequence relay NO 100000 cycles at maximum switching current
Refresh time	Relay output R1, R2 : 5 ms (+/- 0.5 ms)
Minimum switching current	Relay output R1, R2 : 5 mA at 24 V DC
Maximum switching current	Relay output R1 : 3 A at 250 V AC on resistive load (cos phi = 1) Relay output R1 : 3 A at 30 V DC on resistive load (cos phi = 1) Relay output R1 : 2 A at 250 V AC on inductive load (cos phi = 0.4 and L/R = 7 ms) Relay output R1 : 2 A at 30 V DC on inductive load (cos phi = 0.4 and L/R = 7 ms) Relay output R2 : 5 A at 250 V AC on resistive load (cos phi = 1) Relay output R2 : 5 A at 30 V DC on resistive load (cos phi = 1) Relay output R2 : 2 A at 250 V AC on inductive load (cos phi = 0.4 and L/R = 7 ms) Relay output R2 : 2 A at 30 V DC on inductive load (cos phi = 0.4 and L/R = 7 ms)

Environment

Isolation	Between power and control terminals
Insulation resistance	> 1 mOhm 500 V DC for 1 minute to earth
Noise level	46.6 dB conforming to 86/188/EEC
Power dissipation in W	Natural convection : 134 W at 380 V, switching frequency 4 kHz (heavy duty) Forced convection : 134 W at 380 V, switching frequency 4 kHz (heavy duty) Natural convection : 164 W at 380 V, switching frequency 4 kHz (normal duty) Forced convection : 164 W at 380 V, switching frequency 4 kHz (normal duty)
Operating position	Vertical +/- 10 degree
Electromagnetic compatibility	1.2/50 μ s - 8/20 μ s surge immunity test level 3 conforming to IEC 61000-4-5 Electrical fast transient/burst immunity test level 4 conforming to IEC 61000-4-4 Electrostatic discharge immunity test level 3 conforming to IEC 61000-4-2 Radiated radio-frequency electromagnetic field immunity test level 3 conforming to IEC 61000-4-3 Conducted radio-frequency immunity test level 3 conforming to IEC 61000-4-6
Pollution degree	2 conforming to EN/IEC 61800-5-1
Vibration resistance	1.5 mm peak to peak (f= 2...19 Hz) conforming to EN/IEC 60721-3-3 class 3M3 1 gn (f= 9...200 Hz) conforming to EN/IEC 60721-3-3 class 3M3
Shock resistance	15 gn (duration = 11 ms) conforming to EN/IEC 60721-3-3 class 3M3
Relative humidity	5...95 % without condensation conforming to EN/IEC 60721-3-3 class 3K3
Ambient air temperature for operation	0...50 °C without current derating (heavy duty) 0...40 °C without current derating (normal duty) 50...60 °C with current derating (heavy duty) 40...60 °C with current derating (normal duty)
Ambient air temperature for storage	-25...70 °C
Operating altitude	<= 1000 m without derating 1000...3000 m with current derating 1 % per 100 m
Environmental characteristic	Chemical pollution resistance class 3C3 conforming to EN/IEC 60721-3-3 Dust pollution resistance class 3S3 conforming to EN/IEC 60721-3-3
Standards	EN/IEC 61800-3 EN/IEC 61800-3 environment 1 category C2 EN/IEC 61800-3 environment 2 category C3 EN/IEC 61800-5-1 IEC 60721-3 IEC 61508 IEC 13849-1 UL 618000-5-1
Product certifications	CSA TÜV UL REACH
Marking	CE

Offer Sustainability

Sustainable offer status	Green Premium product
RoHS (date code: YYWW)	Compliant - since 1635 - Schneider Electric declaration of conformity Schneider Electric declaration of conformity
REACH	Reference not containing SVHC above the threshold Reference not containing SVHC above the threshold
Product environmental profile	Available Product Environmental Profile
Product end of life instructions	Available End of Life Information

Dimensions

Views: Front - Left - Rear

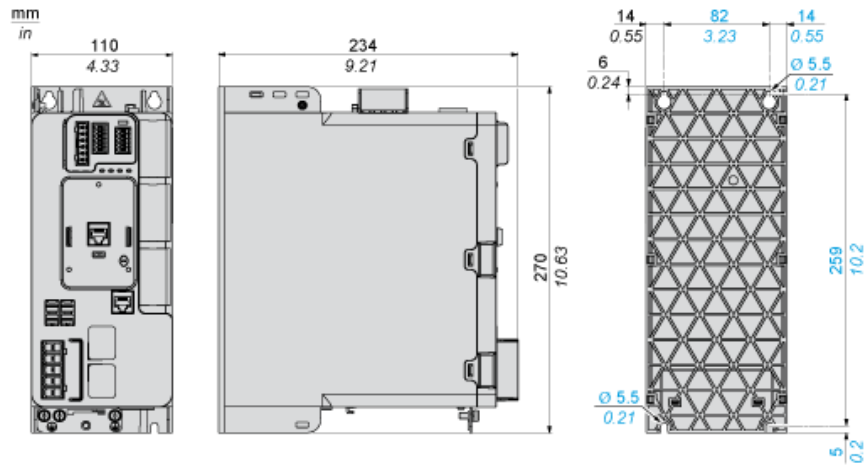

Clearance

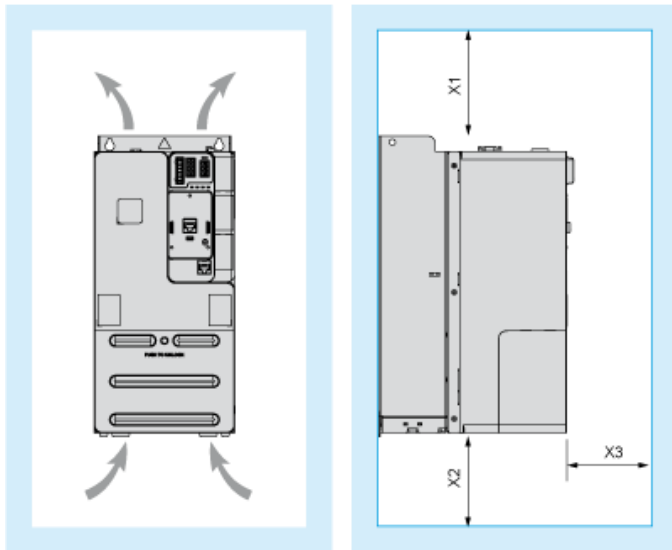

Dimensions in mm

X1	X2	X3
100	100	60

Dimensions in in.

X1	X2	X3
3.94	3.94	2.36

Mounting Types

Mounting Type A: Side by Side IP20

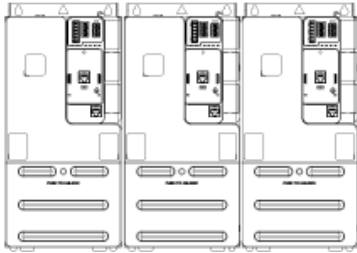

Possible, at ambient temperature $\leq 50\text{ }^{\circ}\text{C}$ (122 $^{\circ}\text{F}$)

Mounting Type B: Individual IP20

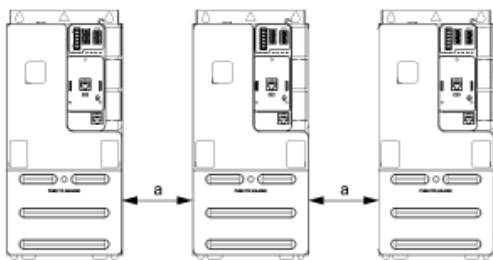

a 50 mm (1.97 in.) from 50...60 $^{\circ}\text{C}$, no restriction below 50 $^{\circ}\text{C}$

Connections and Schema

Three-phase Power Supply with Upstream Breaking via Line Contactor Without Safety Function STO

Connection diagrams conforming to standards ISO13849 category 1 and IEC/EN 61508 capacity SIL1, stopping category 0 in accordance with standard IEC/EN 60204-1.

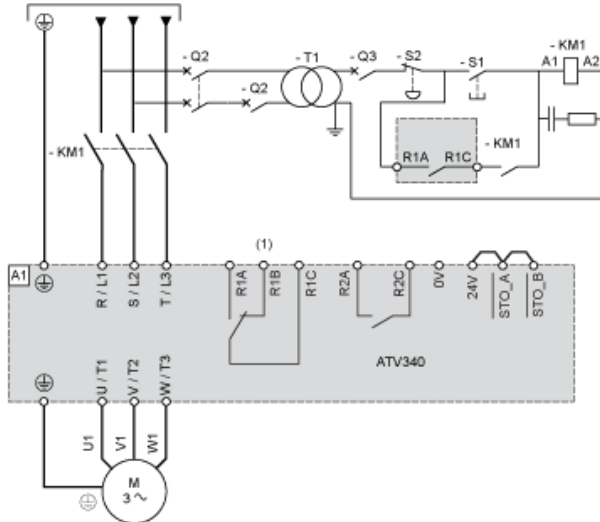

- (1) Use relay output R1 set to operating state Fault to switch Off the product once an error is detected.
A1 : Drive
KM1 : Line Contactor
Q2, Q3 : Circuit breakers
S1 : Pushbutton
S2 : Emergency stop
T1 : Transformer for control part

Three-phase Power Supply With Downstream Breaking via Switch Disconnecter

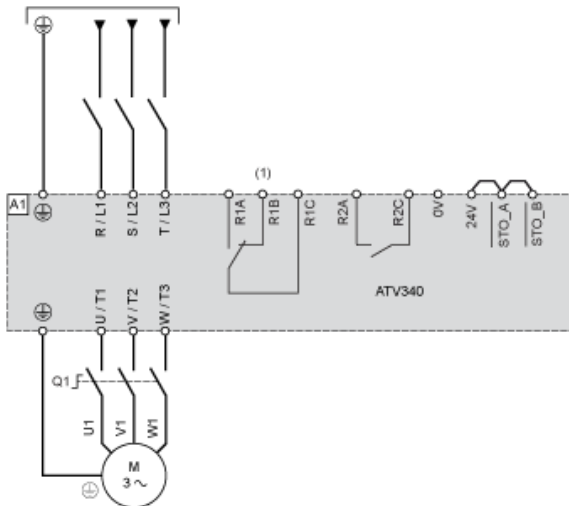

- (1) Use relay output R1 set to operating state Fault to switch Off the product once an error is detected.
A1 : Drive
Q1 : Switch disconnecter

Sensor Connection

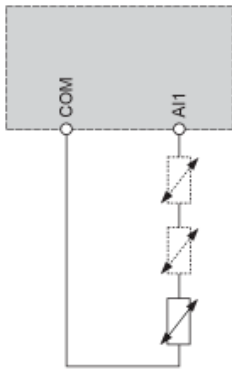

It is possible to connect either 1 or 3 sensors on terminals AI1.

Control Block Wiring Diagram

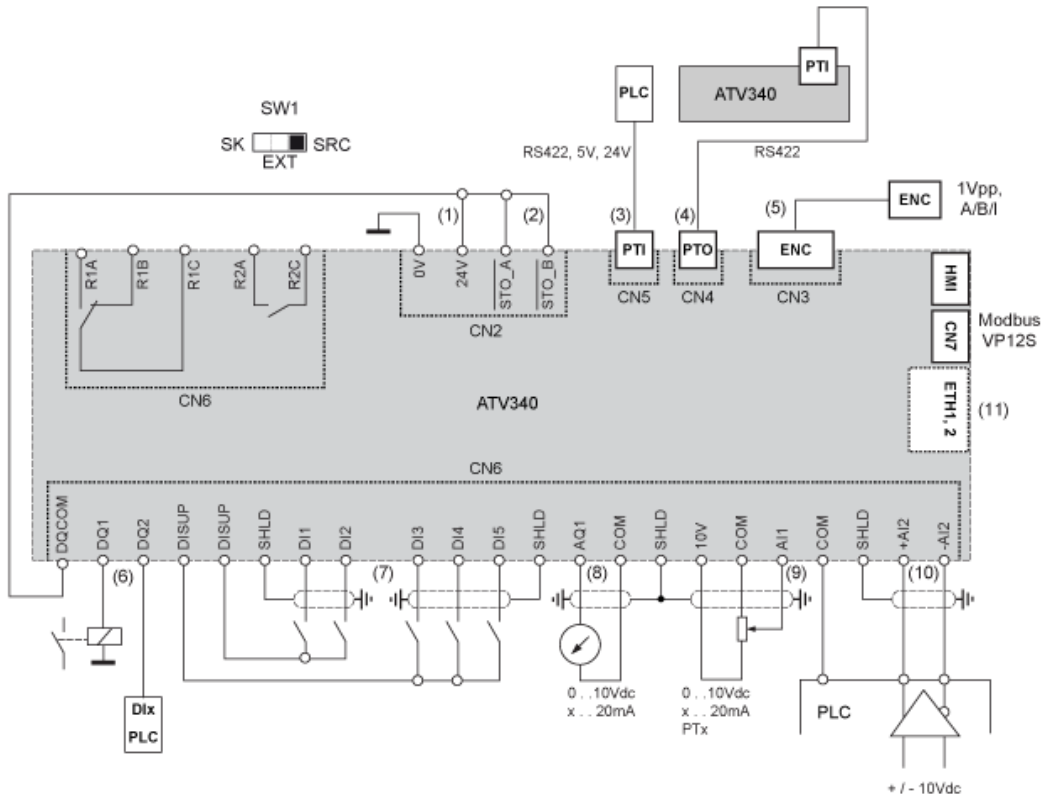

- (1) 24V supply (STO)
- (2) STO - Safe Torque Off
- (3) PTI - Pulse Train In
- (4) PTO - Pulse Train Out
- (5) Motor Encoder connection
- (6) Digital outputs
- (7) Digital inputs
- (8) Analog output
- (9) Analog input
- (10) Differential Analog Input
- (11) Ethernet port (only on Ethernet drive version)

SW1 : Sink/Source switch

R1A, R1B, R1C Relay

R2A, R2C Sequence relay

Digital Inputs Wiring

Digital Inputs: Internal Supply

Using DISUP Signal

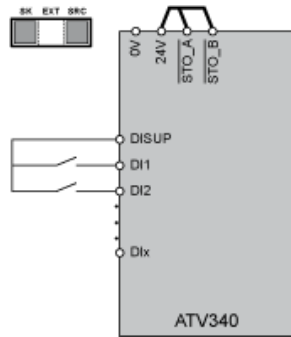

In SRC position DISUP outputs 24 V. In SK position DISUP is connected to 0 V.

Digital Inputs: External Supply

Positive Logic, Source, European Style

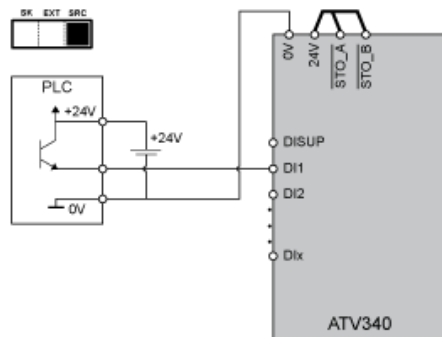

Negative Logic, Sink, Asian Style

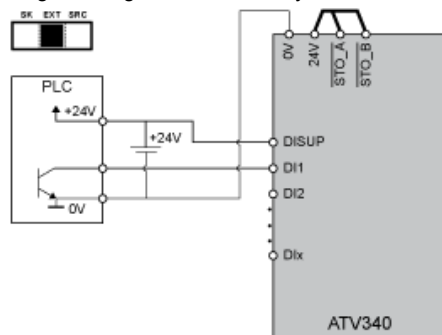

Digital Inputs: Internal supply

Negative Logic, Sink, Asian Style

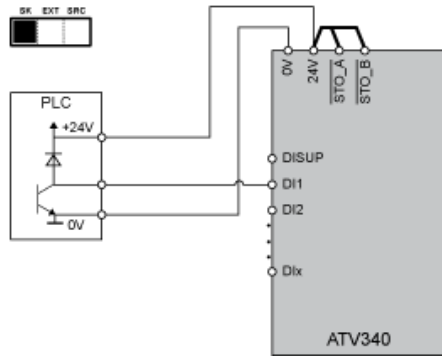

Digital Outputs Wiring

Digital Outputs: Internal Supply

Positive Logic, Source, European Style, DQCOM to +24V

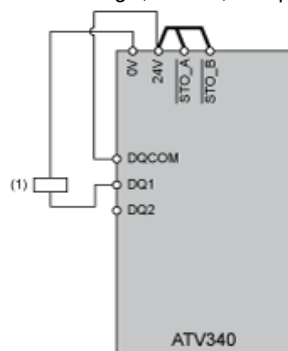

(1) Relay or valve

Negative Logic, Sink, Asian Style, DQCOM to 0V

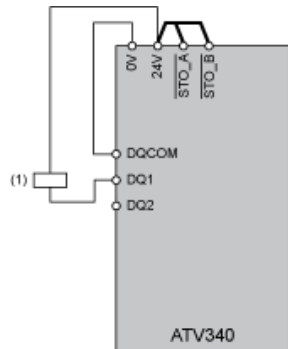

(1) Relay or valve

Digital Outputs: External Supply

Positive Logic, Source, European Style, DQCOM to +24V

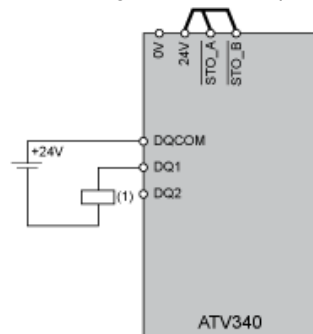

(1) Relay or valve

Negative Logic, Sink, Asian Style, DQCOM to 0V

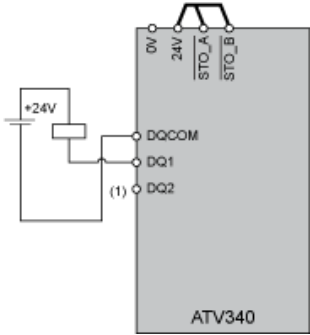

(1) Relay or valve

Derating Curves

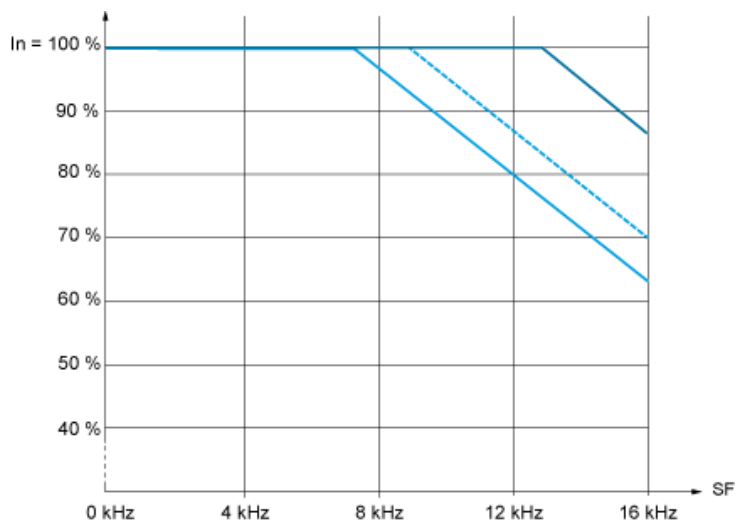

- 40 °C (104 °F) - Mounting type A and B
 - - - 50 °C (122 °F) - Mounting type A and B
 - 60 °C (140 °F) - Mounting type B
- In : Nominal Drive Current
SF : Switching Frequency